

REPLACEMENT INSTRUCTIONS FOR AWNING

■ Fabric ■ Roller Tube ■ Torsion Assembly

For Models 5000, 7000, 7500, 8000, 8500, 9000, 9500 & Grande Pavilion

Tools Required:

Vise Grips®
Socket Wrench Set
3/16" Drill Bit
1/8" Pop Rivets

Screwdriver
Electric Drill
Step Ladder
3/16" Pop Rivets

Pop Rivet Tool
Adjustable Wrench
1/8" Drill Bit
Small File

A. GENERAL INSTRUCTIONS

The Fabric Roller Tube Assembly (FRTA) consists of a fabric, a roller tube and torsion assemblies.

For proper awning operation, the roller is under spring tension from the torsion assemblies. **Improper release of this spring tension can result in damage to the awning, severe personal injury, or both.**

Service to the FRTA should be performed *ONLY* by a qualified service person.

Read and understand the instructions before starting the replacement of a fabric, a roller tube or a torsion assembly.

B. REMOVAL OF THE AWNING FROM THE COACH

NOTE: Awning removal from the coach is NOT necessary when replacing a torsion assembly. Proceed to Section C, Steps 1 & 2, Sections D, Steps 1-3, and Section L, Steps 1-3.

1. In all instances of fabric or roller tube replacement, it will be necessary to have a large work area to allow complete unrolling of the awning. This work area must be clean and smooth so the fabric will not be damaged.
2. Remove the TEK screws securing the awning fabric or roller cover at each end of the awning rail. See FIG. 1.
3. Remove both top mounting brackets on the ends of the awning rail. See FIG. 1.

4. Remove both of the patio feet from their mounting brackets and extend the adjustable arms until each patio foot rests on the ground and lock button locks in hole.
5. Slide the awning fabric or roller cover out of the awning rail.
 - a. To keep the 7500, 8000, 8500, 9000, 9500 and Grande Pavilion Model Awning from unwinding during this step, be sure the cam lock lever is in the roll down position. A 1/8" cotter pin can be inserted in each torsion assembly for positive locking of the roller tube. See FIG. 2.

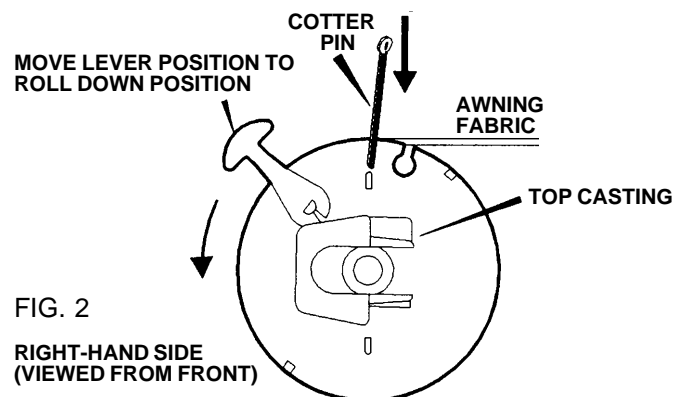
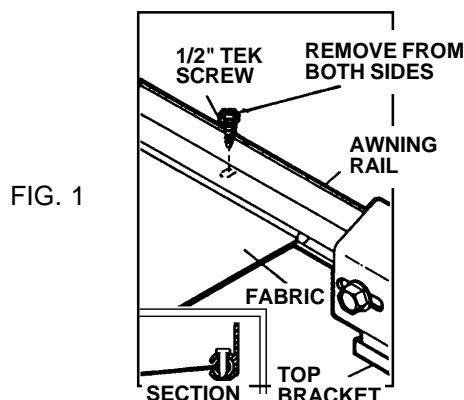

- b. To keep the 5000 or 7000 Model Awning from unwinding, it must be pinned. See FIGS. 3 & 3A.

NOTE: Some 5000 and 7000 Model Awning torsion assemblies can not be pinned. If you have this type, the torsion spring must be unwound before the awning can be removed from the coach. Follow the instructions in Section C, Steps 1 and 2.

FIG. 3 **5000 MODEL AWNING**

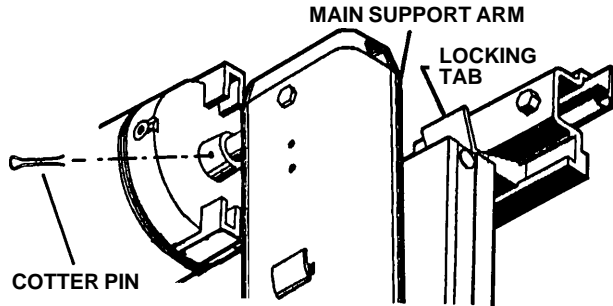
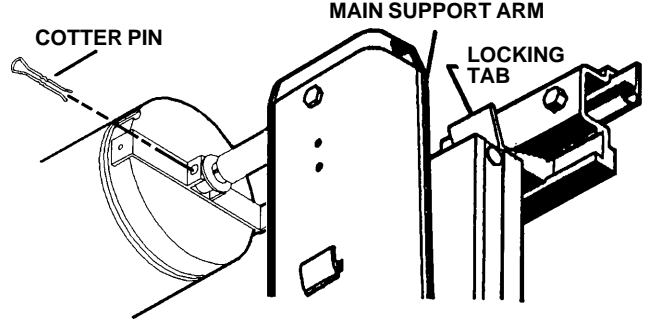

FIG. 3A **7000 MODEL AWNING**



C. UNWINDING A TORSION ASSEMBLY SPRING

NOTE: If the awning is installed on a coach, complete the following steps on a step ladder, with the awning fabric unrolled two feet from the awning rail.

1. Clamp a Vise Grip® tightly on the top casting. Remove the 1/4-20 hex head machine screw from the top casting. See FIG. 4.

WARNING

Severe injuries can result from the rapid spin-off of the top casting. Use Vise Grips® - NEVER use bare hands - to handle a top casting under spring tension.

2. Take the top casting carefully out of the main support arm (see NOTE below). Slowly let the torsion spring unwind completely. Repeat Steps 1 & 2 for the opposite end.

NOTE: If the awning's right-hand torsion assembly has been pinned (5000 & 7000 Models), the cotter pin must be removed from the torsion assembly before the spring can be unwound. If the awning is an 8000, 8500, 9000, 9500 or Grande Pavilion Model, the cam lock lever on the right-hand torsion assembly must be turned clockwise to the roll up position, before the spring can be unwound.

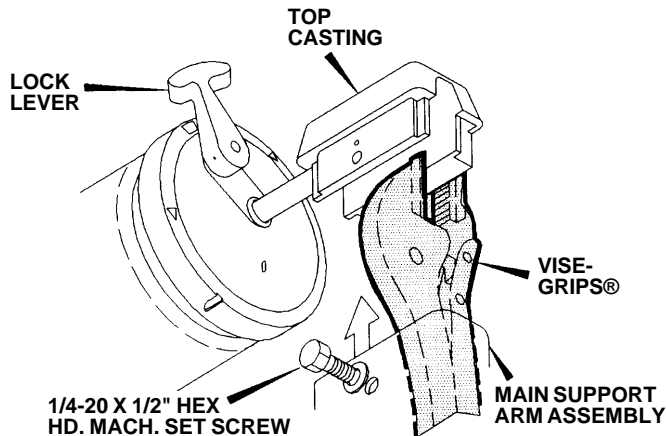
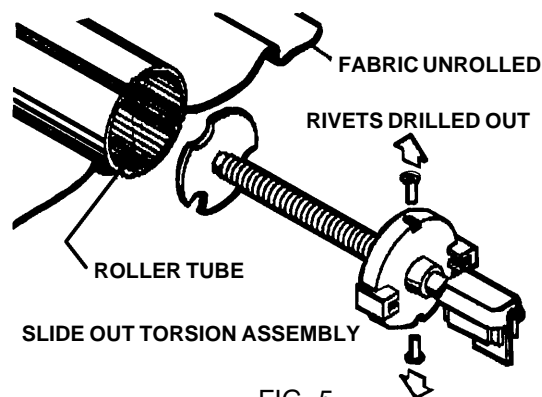

FIG. 4

D. HOW TO REMOVE A TORSION ASSEMBLY

1. Make sure the torsion spring has been relieved of its tension (see Section C.)
2. Mark or make note of the location of the fabric and the end cap on the roller tube. This is necessary to reposition the new torsion, fabric or roller tube exactly the same when the new part is installed.
3. Remove the two screws holding the torsion assembly to the roller tube. If secured by pop rivets, drill out the two rivets using a 3/16" drill bit. Remove assembly from roller tube. See FIG. 5.



E. HOW TO REMOVE FABRIC FROM ROLLER TUBE

1. Remove both torsions. See Section D, Steps 1-3 for torsion removal.
2. Roll the awning completely out on a clean smooth surface.
3. With the awning laying flat, slide the roller tube out from fabric.

NOTE: When removing the fabric from the 9000 and 9500 Model awning, it is necessary to remove the 1/8" pop rivets from both ends of the roller cover. Once the rivets are removed, you can slide the fabric out of the cover. See FIG. 6 & 7.

F. INSTALLING FABRIC ON ROLLER TUBE

1. Unfold the new fabric and lay it on top of the existing fabric in the **exact same position**. Be sure the new fabric is the correct size and color. If roller tube is being replaced, make sure it is the correct length and position it the same as the original.
2. Guide the roller tube over the poly-rope(s) of the fabric. Be careful not to damage the roller tube or the fabric.

NOTE: When changing the fabric, it is vital that the same groove(s) be used. This eliminates the need to redrill any holes (i.e. center support).

3. Center the fabric on the roller tube and hand-roll the entire assembly in the same direction as the original fabric.

G. FABRIC REPLACEMENT ON 9000 WITH 7 SLAT ROLLER COVER

Installing a new replacement fabric on a Model 9000 roller cover with 7 slats and a vinyl strip. See FIG. 6:

1. Remove vinyl strip **A** (FIG. 11) and hinge slat **B** (FIG. 10) from top slat **C** (FIG. 8). Discard both vinyl strip **A** and hinge slat **B**.
2. Remove top slat **C** (FIG. 8) from roller cover assembly and keep to be installed later.
3. The new replacement fabric will be installed as shown in FIG. 7.
4. Use a small file to round the ends of the groove in the 5/16" channel of the main slat **D** (FIG. 9).
5. Slide the 5/16" channel of the main slat **D** onto the poly-rope located approximately 12" from the top edge of the fabric.

6. Install two pop rivets in the main slat **D** on both ends to prevent the fabric from shifting in roller cover. If a new roller cover assembly is being installed, a 1/8" hole will need to be drilled 1-1/2" to 2" from end of the main slat for the pop rivets. To prevent damage, be sure to remove any burrs left by the drill.
7. Use a small file to round the ends of the 5/16" grooves on the top slat **C** (FIG. 8) to prevent tearing of the fabric. Slide the top slat **C** onto both the 1/4" channel of the fifth main slat **D** and the poly-rope 1-1/2" from the edge of the fabric.
8. Install the screws into the edge of the roller cover assembly. See FIG. 7.

FIGURES 6 THROUGH 11

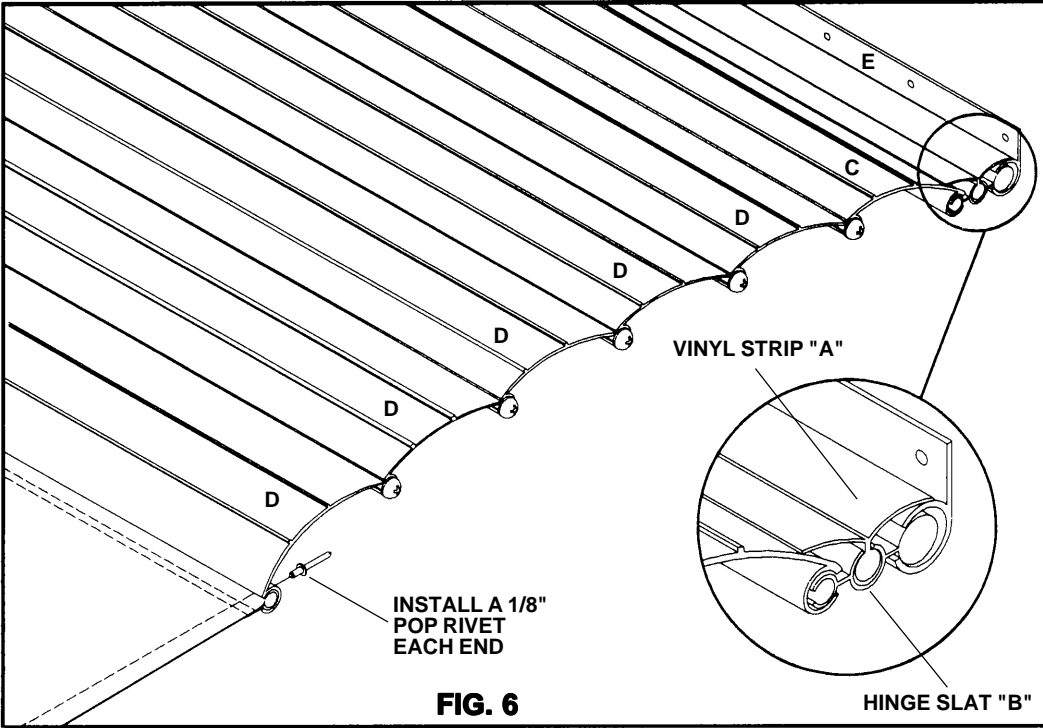

FOR FIGS. 6—11

A - VINYL STRIP
B - HINGE SLAT
C - TOP SLAT
D - MAIN SLAT
E - AWNING RAIL

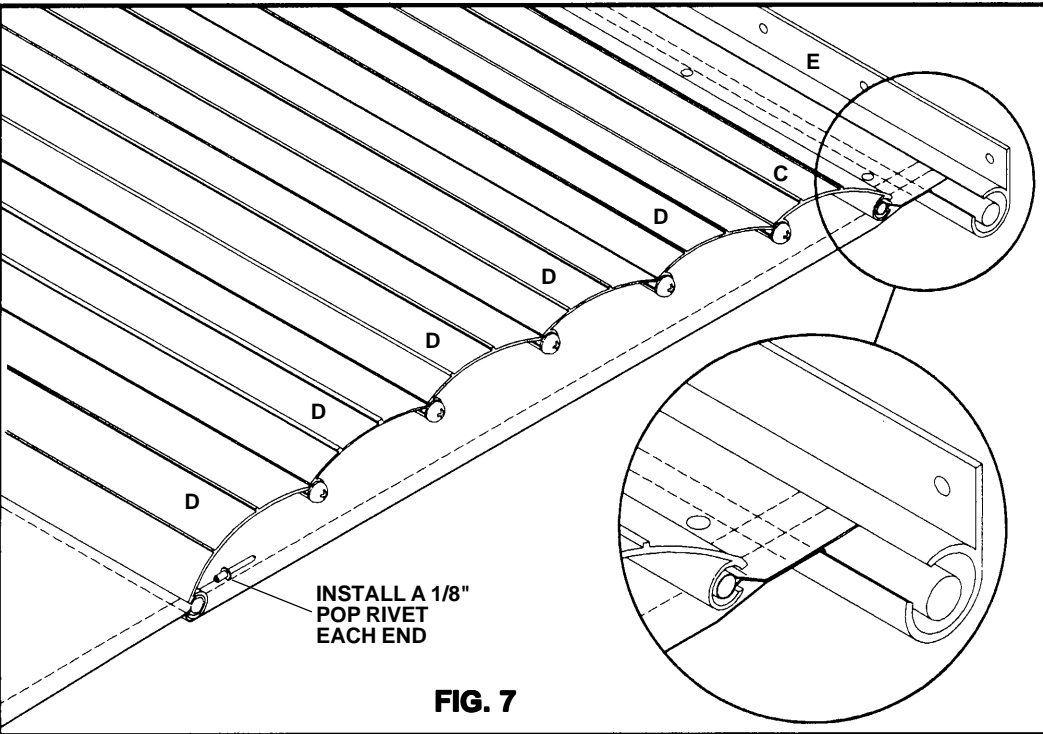

TOP SLAT "C"
VIEW RH END

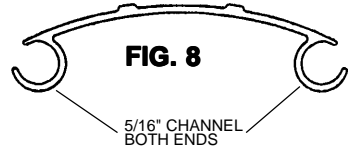

MAIN SLAT "D"
VIEW RH END

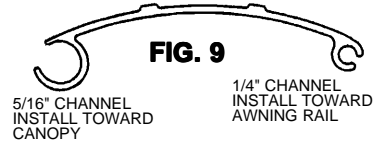

HINGE SLAT "B"



VINYL STRIP "A"



H. FABRIC REPLACEMENT ON 9000/9500 WITH 6 SLAT ROLLER COVER

Installing a new replacement fabric on 9000 and 9500 model awning roller cover with 6 slats. See FIG. 7.

1. Follow steps 2-8 in Section G.

I. INSTALLING NEW ROLLER COVER WITH 7 SLATS & VINYL STRIP

Installing new roller cover on 9000 model with 7 slats and a vinyl strip. See FIG. 6.

1. Use a file to round the ends of the groove in the 5/16" channel of the main slat **D** (FIG. 9).

2. Slide the 5/16" channel of the main slat **D** onto the poly-rope.
3. Drill a 1/8" hole 1-1/2" to 2" from end of the main slat. Install a 1/8" pop rivet. Do both ends to secure the fabric.

J. INSTALLING NEW ROLLER COVER WITH 6 SLATS

Installing new roller cover on model 9000 and 9500 with 6 slats. See FIG. 7.

1. Follow steps 1-8 in Section G.

K. REPLACING TORSION ASSEMBLIES

1. Fold the poly-rope ends into the roller tube. This prevents the fabric from shifting. Make sure the ends of the poly-rope do not interfere with the cam lock.
2. Reinstall the torsion assembly in the roller tube. Align the screw/rivet slots on the end cap with the holes in the roller tube - in the exact same position as in Section D, Step 2.

NOTE: If the roller tube is new, the rivet holes are not drilled. The torsion assemblies must be positioned as follows:

All Models (except the 5000): The left-hand torsion assembly position has the slotted groove in the end cap aligned with the empty groove of the roller tube.

All Models (except the 5000, 9500 & Grande Pavilion): The right-hand torsion assembly position has the slotted groove in the end cap aligned with the empty groove in the roller tube.

On the right-hand torsion assembly for the 9500 & Grande Pavilion: Align the slot in the end cap with the next slot counterclockwise (as viewed from the right end) from the empty slot.

On the 5000 Awning: The lug on the left-hand torsion assembly should be positioned at "11:00" and the right-hand at "1:00" in relationship to the empty groove. See FIG. 12.

NOTE: Placing the end caps as suggested usually positions the lock lever or lugs in the proper position when awning is closed. The awning should be opened and closed several times, and checked. The models with the cam lock lever should be at "11:00" and the lugs of the 5000 and 7000 models should be at the "12:00" position. The end cap may have to be removed and repositioned if it is not in the proper location. See FIG. 13.

!CAUTION

Models 8500 and 9000 22' - 25' have been manufactured with both standard and heavy duty torsion springs. Before reinstalling the torsion, properly identify (Standard or Heavy Duty) the springs. This is necessary for proper winding of the torsion. See Spring Identification Chart on page 6.

FIG. 12

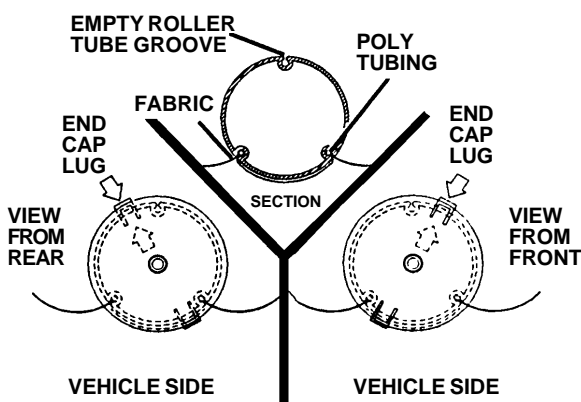

Secure torsion assemblies to roller using 3/16" dia. x 3/8" long stainless steel pop rivets. **NOTE:** DO NOT reuse self-tapping screws.

FIG. 13

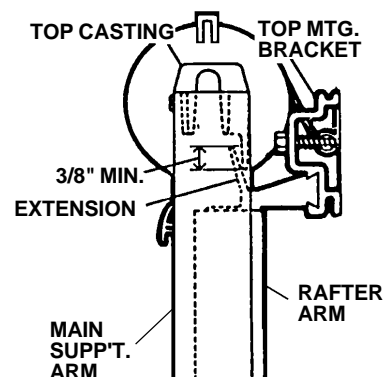

L. REWINDING TORSION ASSEMBLY SPRING

NOTE: If the awning is installed on a coach, complete the following steps on a step ladder with the awning fabric unrolled two feet from the awning rail.

1. Clamp a Vise Grip® tightly on the thickest side of the top casting. See FIG. 4.

WARNING

Severe injury can result from the rapid spin-off of the top casting. Use Vise Grips® - NEVER use bare hands - to handle a top casting under spring tension.

2. Rewind the torsion assembly to the number of turns indicated by the torsion assembly Torque Chart and in the direction shown in FIGS. 14 & 15.

3. Place a 1/8" cotter pin through the hole in the end cap and torsion rod. This will prevent the rapid spin-off of the top casting during installation of the awning. See FIGS. 2, 3 & 3A.

NOTE: If awning is installed on the coach, place the top casting in the support arm and secure with the 1/4-20 hex head bolt.

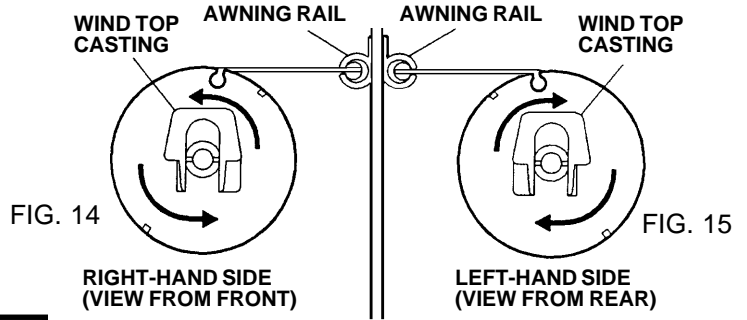

TORSION ASSEMBLY TORQUE SPECIFICATIONS				
Awning Length (Ft.)	Number of Turns			
	MODEL NUMBER			
	5000	7000	7500 8000 8500 9000	9500 Grande Pavillion
8	6	-	8	-
9	6	-	8	-
10	6	8	8	-
10' 8"	6	8	8	-
11	6	8	8	-
12	6	8	8	-
13	7	9	9	-
14	7	9	9	-
15	8	10	10	-
16	8	10	10	6
16'6"	-	-	12	-
17	10	12	12	6
18	10	12	12	7
19	11	13	13	7
19'6"	-	-	13	-
20	11	13	13	-
21	11	13	13	8
22	12	-		8
23	12	-		8
24	12	-		9
25	12	-		9



See Spring Identification Chart for No. of Turns

SPRING IDENTIFICATION CHART		
	Standard	Heavy Duty
Wire Dia.	.120	.140
RH	Painted red cap end and no paint on stabilizer end.	Painted red cap end and white on stabilizer end.
LH	No paint on either end.	Painted white on cap end and no paint on stabilizer end.
Length	URNS OF TENSION	
22'	14	8
23'	14	8
24'	14	8
25'	14	8

M. INSTALLING AWNING ON COACH

1. Follow installation instructions for the awning when replacing on coach.